



**REALPIANO**  
**D I G I T A L**

**PRO 1**

---

**PRO 2**



# General safety instructions

---

## Power source

- Be sure that you are using a Generalmusic approved power adaptor to power the instrument

## Handling the power cord

- Never touch the power adaptor or its plug with wet hands.
- Never pull on the cord to remove it from the wall socket, always pull the plug.
- Never forcibly bend the power adaptor's cord.
- If the power adaptor or its cord is scarred, cut or broken, or has a bad contact, it will be a potential fire hazard or source of serious electric shock. NEVER use a damaged power adaptor; replace it immediately with the correct replacement type.

## If water gets into the instrument

- Remove the adaptor from the wall socket at once, and contact the store where the unit was purchased.
- The top surface of your instrument should never be used as a shelf for flower vases and other containers which hold liquids.

## Metal items etc. inside the unit

- Do not allow metal items or other materials to fall inside the unit.

## Metal items may result in electric shock or damage

- Be especially careful with regards to this point when children are near the unit. They should be warned never to try to put anything inside, and never to slide a hand into the unit while you or other persons are playing.
- If articles do fall inside, remove the power adaptor from the wall socket at once and, if necessary, contact the store where the unit was purchased.
- As a general precaution, never open the unit and touch or tamper with the internal circuitry.

## If the instrument does not seem to be working correctly

- Turn off the power immediately, remove the power adaptor from the mains outlet and contact the store where the instrument was purchased.
- Discontinue using the unit at once. Failure to do so may result in additional damage or other unexpected damage or accident.

## General user maintenance

- Clean the cabinet and keys of your PRO 1 or PRO 2 using a soft, clean, slightly damp cloth and polish with a soft, dry cloth.
- Never use industrial cleaners, detergents, abrasive cleansers, waxes, solvents or polishes as they may damage the instrument finish.
- Always turn off the power supply after use and never turn the unit on and off repeatedly in quick succession as this places an undue load on the electronic components.

---

Generalmusic on Internet: <http://www.generalmusic.com>

The information in this publication has been carefully prepared and checked. The manufacturers however decline all liability for eventual errors. All rights are reserved. This publication may not be copied, photocopied or reproduced in part or in whole without prior written consent from Generalmusic S.p.A. Generalmusic reserves the right to apply any aesthetic, design or function modifications it considers necessary to any of its products without prior notice. Generalmusic declines all liability for damage to property or persons resulting from improper use of the instrument.

Make sure that all internal electronic options are installed by an authorized Generalmusic service technician. Check with an authorized Generalmusic dealer for information on the closest service centre.

Generalmusic © 1996. All rights reserved.

---

# Table of contents

## Section 1: Instrument Layout

Front panel layout;	
PRO 1 .....	4
PRO 2 .....	5
Back panel .....	6
Power and headphones .....	7
Pedal connections .....	8

## Section 2: Quick Study Guide

Sounds and effects .....	10
Performances .....	12

## Section 3: Basic Features

Sounds and performances .....	16
Tuning and tone controls .....	18
Effects and touch .....	20
Other controls .....	22

## Section 4: Performance Edit

List of functions .....	24
Special features .....	28

## Section 5: Master/Midi

Midi functions .....	30
Master functions .....	32

## Section 6: Sequencer / Recorder

Description of controls .....	36
Recording .....	37
Advanced features .....	40

## Section 7: Reference

Technical specifications;	
PRO 1 .....	43
PRO 2 .....	44
Description of technology .....	45
Alphabetical index .....	47

## Appendix

MIDI Implementation chart;	
PRO 1 .....	iii
PRO 2 .....	v
Special Control Messages;	
PRO 1 .....	iv
PRO 2 .....	vi
PRO 2 Effects Selection .....	vii



---

# *Section 1*

## **Instrument Layout**

---

# Front and rear panel

## Front panel - PRO 1

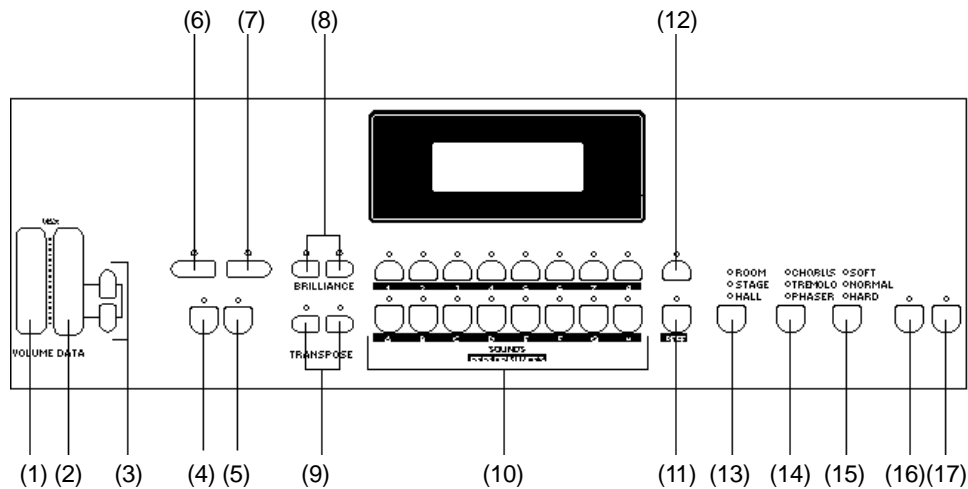

- (1) **VOLUME SLIDER** Controls the main volume of the instrument.
- (2) **DATA SLIDER** Adjusts values shown in the display when using programmable functions.
- (3) **PAGE UP/DOWN**  **BUTTONS** Use these buttons to step through the various functions in the PERF EDIT and MASTER/MIDI menus.
- (4) **MASTER/MIDI** This button provides access to the various MIDI functions of the instrument plus some additional master features such as "Restore Performances" and "EQ Lock".
- (5) **PERF EDIT** Use this button to edit a variety of performance features such as reverb and effect levels, pedal functions and alternative tunings. Any changes made here will be memorized when the performance is saved.
- (6) **STORE** Press this button when you are ready to store the changes you have made. Complete storage by choosing a bank, (A-H) and a program, (1-8).
- (7) **SPLIT** Turning this button on will split the keyboard into separate left and right parts. While the button is held you can choose the split note and the lower, (left) sound.
- (8) **BRILLIANCE** Use these buttons to adjust the overall tone of the instrument.
- (9) **TRANSPOSE** Increases or decreases the overall pitch of the instrument in half-step, (semitone) increments
- (10) **SELECTION BUTTONS** Use these buttons to select sounds or performances, (depending on the state of the SOUNDS/PERF button).
- (11) **SOUNDS/PERF** This button switches between SOUNDS mode and PERFORMANCE mode.
- (12) **VARIATION** Pressing this button in SOUNDS mode will provide a variation of the current sound.
- (13) **REVERB** Use this button to select a reverb type. When all LEDs are off the reverb is cancelled.
- (14) **EFFECT** Use this button to select an effect type. When all LEDs are off the effects are cancelled.
- (15) **TOUCH** This button adjusts the touch of the keyboard according to your playing style.
- (16) **LOCAL OFF** This disconnects the keyboard from the internal voices allowing the instrument to be connected in a "midi loop", (a typical configuration for using external sequencers.)
- (17) **DEMO** Activates the factory programmed demonstration of the internal sounds.

## Front panel - PRO 2

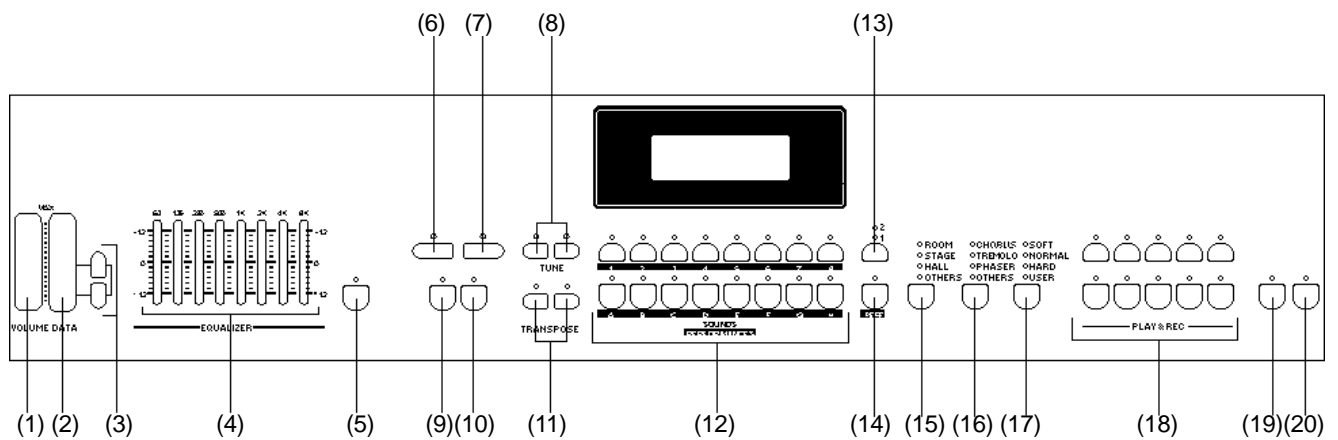

- (1) VOLUME SLIDER** Controls the main volume of the instrument.
- (2) DATA SLIDER** Adjusts values shown in the display when using programmable functions.
- (3) PAGE UP/DOWN  BUTTONS** Use these buttons to step through the various functions in the PERF EDIT and MASTER/MIDI menus.
- (4) EQ SECTION** Provides accurate control of the instrument's tone.
- (5) EQ ON/OFF** Activates and deactivates the EQ section.
- (6) STORE** Press this button when you are ready to store the changes you have made. Complete storage by choosing a bank, (A-H) and a program, (1-8).
- (7) SPLIT** Turning this button on will split the keyboard into separate left and right parts. While the button is held you can choose the split note and the lower, (left) sound.
- (8) TUNE** Use these buttons to adjust the tuning of the instrument.
- (9) MASTER/MIDI** This button provides access to the various MIDI functions of the instrument plus some additional master features such as "Restore Performances" and "EQ Lock".
- (10) PERF EDIT** Use this button to edit a variety of performance features such as reverb and effect levels, pedal functions and alternative tunings. Any changes made here will be memorized when the performance is saved.
- (11) TRANSPOSE** Increases or decreases the overall pitch of the instrument in half-step, (semitone) increments
- (12) SELECTION BUTTONS** Use these buttons to select sounds or performances, (depending on the state of the SOUNDS/PERF button).
- (13) VARIATION** Pressing this button in SOUNDS mode will provide two variations of the current sound.
- (14) SOUNDS/PERF** This button switches between SOUNDS mode and PERFORMANCE mode.
- (15) REVERB** Use this button to select a reverb type. When all LEDs are off the reverb is cancelled.
- (16) EFFECT** Use this button to select an effect type. When all LEDs are off the effects are cancelled.
- (17) TOUCH** This button adjusts the touch of the keyboard according to your playing style. Selecting USER allows you to vary the touch with the DATA slider.
- (18) PLAY AND RECORD** The on board digital recording section, (sequencer) allows you to record what you play. See the dedicated "Sequencer/recorder" section of this manual for more details.
- (19) LOCAL OFF** This isolates the keyboard from the internal voices allowing the instrument to be connected in a "midi loop", (a typical configuration for using external sequencers.)
- (20) DEMO** Activates the factory programmed demonstration of the internal sounds.

## Rear panel - PRO 1 / PRO 2

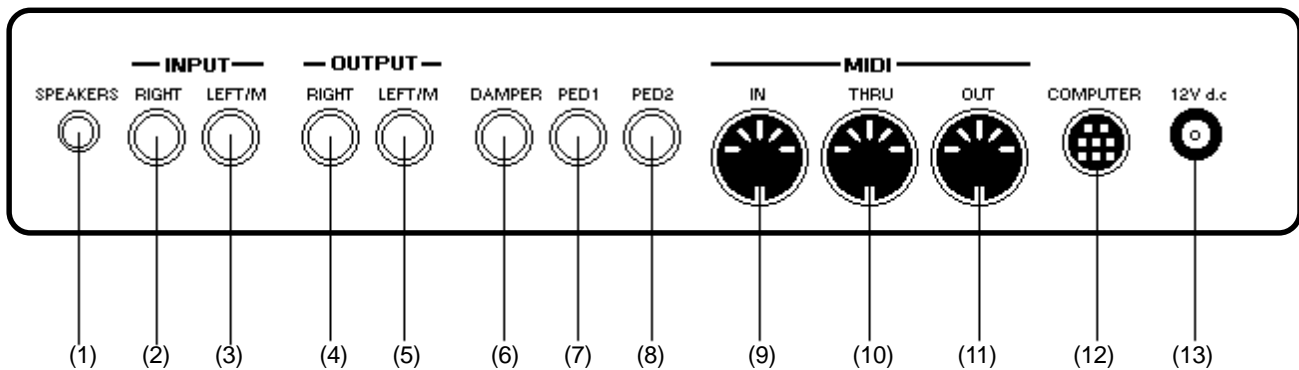

- (1) SPEAKER JACK** This jack allows you to connect a pair of multimedia monitor speakers for practice. This output offers a small amount of power to drive the speakers at a low level.
- (2) RIGHT INPUT**
- (3) LEFT /MONO INPUT** You can use these inputs to connect another instrument or sound module to the piano. The output of the other instrument will be mixed with the main signal of the piano and sent to the OUTPUT, SPEAKER and HEADPHONE jacks. If you are connecting a mono signal, (e.g. a microphone) then you should use only the Left/Mono connector.
- (4) RIGHT OUTPUT**
- (5) LEFT/MONO OUTPUT** These outputs are used to connect the instrument to an amplifier, mixer or recording device in stereo. If you are connecting to mono equipment, (e.g. a guitar amplifier) then you should use only the Left/Mono connector.
- (6) DAMPER** You can connect either a standard footswitch or the special Real Piano Continuous Damper Pedal, (available from your Generalmusic dealer) to simulate the right pedal of a piano.
- (7) PEDAL 1**
- (8) PEDAL 2** Each socket can accept either a footswitch or a continuous, (volume) type pedal. The function for each pedal can be selected in the PERF EDIT section.
- (9) MIDI IN** Allows the sounds of the PRO1/2 to be played by an external device e.g. a controller keyboard or a sequencer.
- (10) MIDI THRU** Provides a copy of the information being received by the MIDI IN. Use MIDI THRU when connecting a number of different instruments together.
- (11) MIDI OUT** Sends MIDI information from the PRO 1/2 to other equipment so that the instrument can be used as a controller.
- (12) COMPUTER JACK** Allows direct connection of the instrument to an IBM or Macintosh computer without the need to use a MIDI interface.
- (13) D.C. POWER JACK** Connection for the power supply unit. Use only the unit supplied with your instrument.

## Power switch and headphones

---

### Power switch

The power switch is located on the back panel at the lower left side. You should always ensure that the power switch is in off position when connecting or disconnecting the power adaptor. Applying power while the switch is on may damage the components inside the unit.

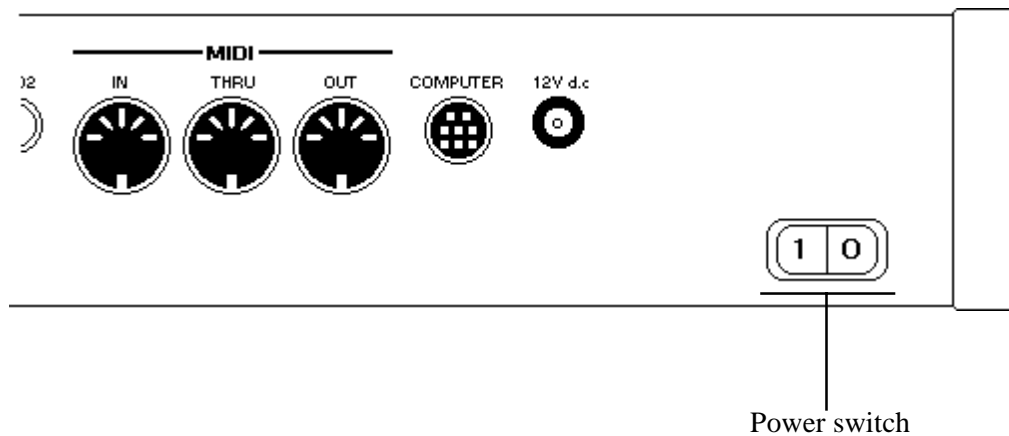

### Headphone jack

The headphone jack is located at the extreme left side of the metal rail which runs beneath the keyboard.

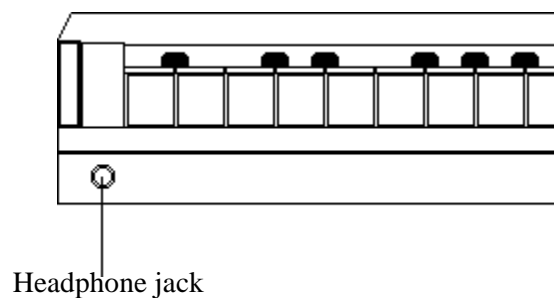

## Pedal connections

---

There are three pedal jacks on the back panel of the PRO 1/PRO 2.

The DAMPER pedal jack can accept any type of generic footswitch to provide a "sustain pedal" effect. It should be noted however that this socket can also accept a special "continuous damper pedal", (available from your Generalmusic dealer), which more faithfully replicates the action of an acoustic piano's damper pedal. When this continuous type of pedal is used, the amount of damping will vary according to the position of the pedal.

The other two pedal jacks, PED1 and PED2, can accept either a pedal switch or a continuous type pedal. These pedals, when connected can be used for a variety of different functions. These functions are detailed in section 4 of this manual - PERF EDIT, Pedal 1 Function/Pedal 2 Function.

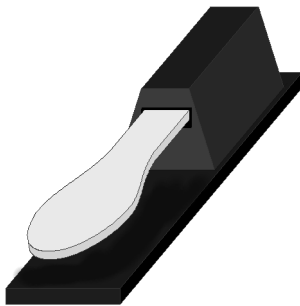

Pedal switch

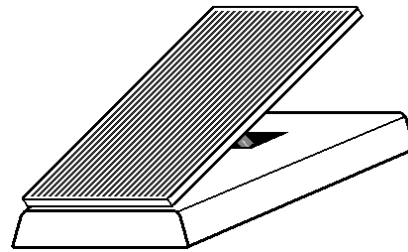

Continuous pedal

### A note about pedals and footswitches

There are four types of pedals which may be connected to the PRO 1/PRO 2;

1. Footswitch - normal polarity, (or "normally open")
2. Footswitch - reverse polarity, (or normally closed")
3. Continuous volume pedal
4. Generalmusic continuous damper pedal

Whenever one of the above pedal types is connected to either the DAMPER, PED 1 or PED 2 jacks the instrument will automatically detect which type of pedal it is. This "auto detect" procedure normally takes about 1-2 seconds. In order for the system to correctly evaluate the pedal type, it is important not to press or move the pedal until the pedal change screen, (Fig. 1) has disappeared.

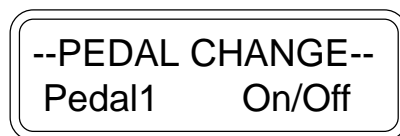

*Fig. 1: Detecting the pedal type*

---

# *Section 2*

## **Quick Study Guide**

---

For those of you who don't like to read manuals or wish to read the manual in detail later, here is everything you need to get started.

## Basic Functions and Features

---

If you are eager to “dive in” to your new keyboard or if you plan to study the manual more carefully at a later date, read this section first to get an overall feel for the basic operation of the PRO1 and PRO2. These instruments follow a simple and logical design so you should be able to use and understand many of the features without exhaustive description. If you need more explanation of a particular feature, you will find a comprehensive description of each function further on in this manual.

### Simple Operation

There are two different ways of using the instrument;

1: SOUNDS mode

2: PERF mode, (“Performance” mode)



Either mode can be selected by use of the SOUNDS/PERF button to the right of the sound selection buttons. When the light above the button is ON, the instrument is in SOUNDS mode. When this light is OFF the instrument is in PERF mode.

SOUNDS mode is used for normal operation of the instrument and this is where you should start if you are new to the instrument. In this mode you can use the sound selection buttons in conjunction with the VAR, (variation) button to choose any desired sound.

You can easily add effects to the selected sound by using the REVERB and EFFECTS buttons.

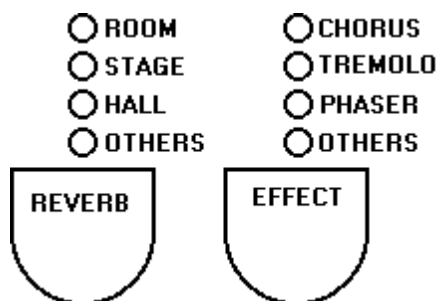

If you want to mix two sounds together, this can be achieved by simply pressing the two required sound buttons together at the same time. You may also split the keyboard by pressing SPLIT. If you select a sound while holding the split button, this assigns that sound to the left side of the keyboard. If you press a key while holding the split button, the note you pressed will become the new split point, (it actually becomes the lowest note of the right or upper section.)

---

If you wish to further edit the sound combination you are making, for example, to adjust the relative volumes of the two sounds or to change the effect send amount for each sound, you can use the features in the PERF EDIT menu.



Pressing PERF EDIT will display one of the many available edit pages allowing you to change some aspect of the current combination. The DATA slider is used to adjust the value of whatever is currently displayed. Other screens can be selected by pressing the PAGE buttons to the right of the DATA slider.

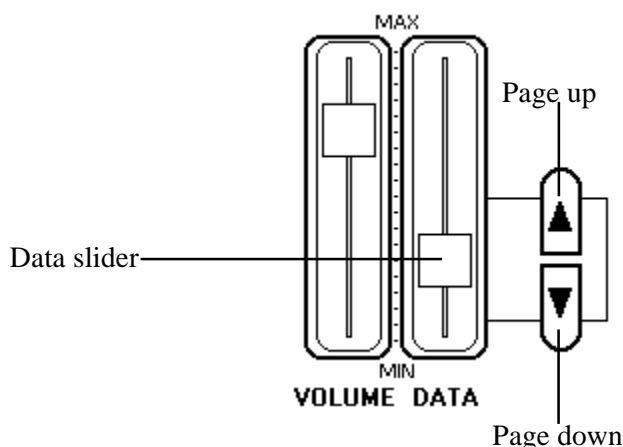

The number of features available in the PERF EDIT menu will be different depending on whether you have one sound or two sounds currently active. When you have two sounds selected, (either mixed together or using a split keyboard), you will see many of the screens twice. For example; if you have two sounds mixed together, the first PERF EDIT screen allows you to adjust the volume of Sound 1 with the DATA slider. When you page forward to the next screen you can now adjust the volume of Sound 2 with the DATA slider. If you had selected only one sound you would not see this second screen.

After you have spent some time adjusting things like the effect levels, mixing, pedal assignments and other features contained in PERF EDIT, you will have created what we call a PERFORMANCE. In simple terms, a PERFORMANCE is just the end result of some tweaking and editing where the instrument now sounds the way you want it to. At this stage your PERFORMANCE can be saved in memory so that you can instantly recall it the next time you need to use it.

## Storing a Performance

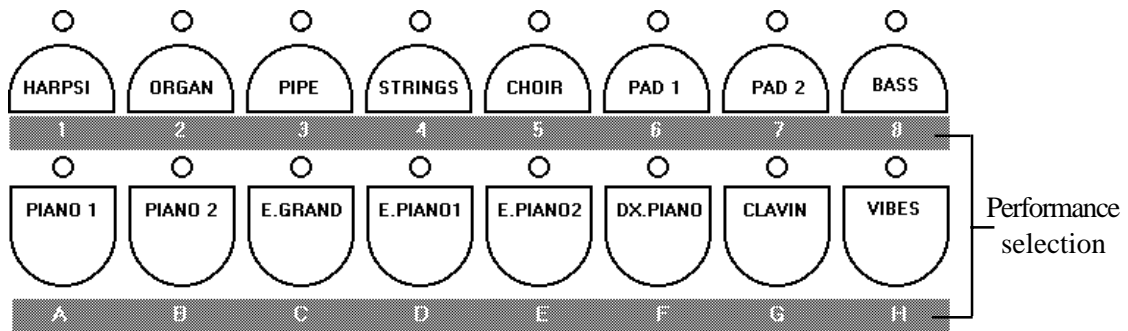

There are 64 PERFORMANCE memories on-board the PRO1 and PRO2. They are arranged in eight banks from A to H. Each bank contains eight Performances numbered 1 - 8. The sound selection buttons are used to select Performances when the instrument is in PERF mode. Beneath each button you will see different coloured print which indicates that button's function when the instrument is in PERF mode. Each Performance has both an alpha-numeric reference, (e.g. C5 or F2), and an actual text name which is displayed in the screen after it has been selected.

Although the procedure for saving and naming a Performance is described in detail elsewhere in this manual, the basic steps are very simple. After creating a performance which you want to store, press the STORE button.



Next, choose the BANK, (A - H), by pressing one of the lower row of sound selection keys. Finally, choose one of the eight locations in that bank by pressing one of the upper row of sound selection keys. Your performance is now stored. You can recall it at any time by activating PERF mode, (SOUNDS / PERF light OFF), and selecting first the BANK letter followed by the location number.

### **EXAMPLE: Saving the current sound settings into Performance "E6"**

With the instrument in SOUNDS mode and a performance ready to be saved;

- 1. Press STORE, (at this stage you can use the DATA slider and the page buttons to enter a text name for this performance)**
- 2. Press "E" (the E. PIANO 2 button)**
- 3. Press "6" (the PAD 1 button)**

You have now stored this sound setting into Performance E6.

When your PRO1 or PRO 2 leaves the factory, many of the performances have been pre-programmed to let you hear some of the possibilities of the instrument. The first of these is a basic piano setting which has been stored in Performance A1. You can listen to some of the instrument's powerful capabilities by listening to the combinations stored in A2, A3, A4 etc. Even if you have erased or overwritten some of these factory performances, they can be fully restored at any time by turning the power on while holding the PERF EDIT button, or by using the RESTORE PERFS function in the MASTER/MIDI section. This function will erase any Performances you had previously saved.

## Making a Performance from scratch

---

Lets try a complete step by step example.

The aim is to make a combination of E. Piano 1, (without variation) and Choir Variation 1. We need the Choir sound to be about half the volume of the Electric Piano. We will add some hall reverb to the sound but we need to have much more reverb on the Choir than on the Electric Piano. When we have finished making this sound combination, we will store it in performance B1.

- 1. Switch the instrument on, (just to be sure that we are really starting from scratch.)*
- 2. While holding E. Piano 1, press Choir.*

This mixes the basic E Piano 1 sound with the basic Choir sound. Now we need to select Choir variation 1 without changing the piano.

- 3. Use the PAGE buttons so that the arrow in the display appears next to the Choir sound.*
- 4. Press the VAR button to select variation 1.*

Now let's add the reverb effect.

- 5. Repeatedly press the REVERB button until the HALL effect is selected.*

At this stage we have mixed our two sounds and selected the effect. This gives us a basic combination. We now need to edit the combination so that each sound has a different volume level and a different amount of reverb.

- 6. Press PERF EDIT*
- 7. If you do not see page 1, use the page buttons to step back to it.*
- 8. Adjust the volume of the E. Piano 1 sound to maximum.*
- 9. Now page forward to Page 1b, (volume for the Choir sound.)*
- 10. Adjust the level to about 64.*
- 11. Use the page buttons to select REVERB SEND for the piano, (Page 2.)*
- 12. Choose a small value such as 40 or 50.*
- 13. Now move to page 2b - REVERB SEND for the Choir.*
- 14. Choose a high value such as 100.*

This completes the editing.

- 15. Press PERF EDIT to turn it off.*

Let's now store this sound combination into performance B1.

- 16. Press STORE*
- 17. Press "B", (PIANO 2 button)*
- 18. Press "1", (HARPSI button)*

That's it. To recall this sound combination at any time, simply switch to PERFORMANCE mode and press "B" followed by "1".

## “Quick Piano” feature

---

Since the PRO 1 and PRO 2 are designed to be played primarily as a piano, both instruments include a function designed to quickly return the instrument to a basic piano sound with no effects.

To activate this “Quick Piano” feature, first hold the PIANO 1 button and then press the SOUNDS/PERF button.

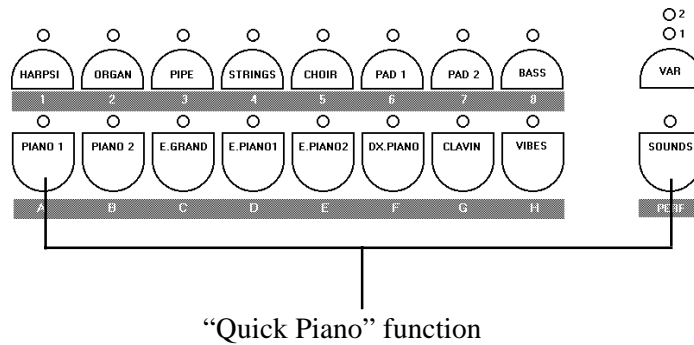

It is important to remember that PIANO 1 must be held down before you press SOUNDS/PERF.

*NOTE: Using “Quick Piano” will not affect any settings which have been stored in the instrument’s memory.*

---

# *Section 3*

## **Basic Features**

---

This section will explain how to approach the instrument for the first time in a simple fashion. It will help you to get quickly acquainted with the most important features of the instrument.

## Selecting sounds

---

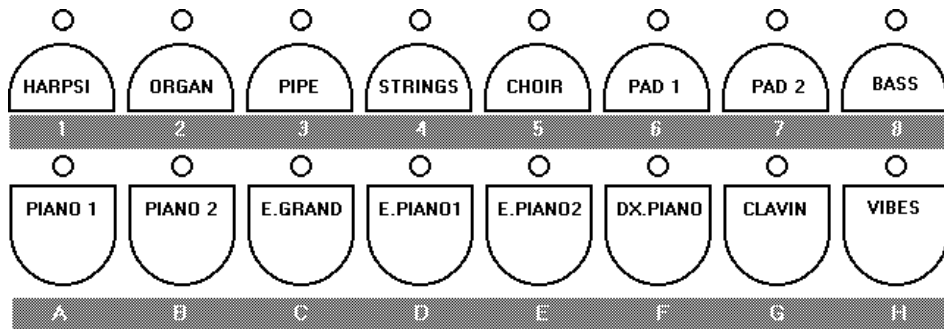

After switching the instrument on, pressing any of the sound selection buttons on the front panel will instantly change the sound. The display will show the name of the sound which is currently selected.

### Variations

On the PRO 1, each sound button actually contains two sounds. The second sound can be selected by pressing the VAR button. Refer to the screen to see the name of the variation sound.

On the PRO 2, each sound button actually contains three sounds. You can use the VAR button to select either variation 1, variation 2 or no variation. Refer to the screen to see the name of the currently selected sound.

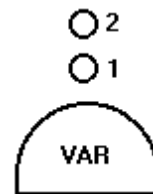

### Mixing sounds together

To mix or “layer” two sounds together, simply press two sound buttons at the same time -for example: Piano 1 and Choir.

Although the volume levels of the two sounds can be adjusted in PERF EDIT, (see section 4), there is a simple method of volume control which can be applied without any editing. When you press two sound buttons, the one you press first will be the loudest. This means that, when mixing Piano and Choir as in the above example, if you held the Choir button and then pressed Piano, the Choir would be louder than the Piano. If you held the Piano button first and then pressed Choir, the Piano would be the loudest.

When mixing two sounds together in this way, you may want to use a different variation for sound 1 and sound 2: for example, mixing Piano 1, (no variation) with Strings Variation 1. To do this, press Piano 1 and Strings at the same time. In the screen you will now see the sound names Piano 1 and Strings displayed one above the other. To the left of one of these names will be an arrow. This arrow points to the “current sound”. You can move the arrow to the other sound by pressing the PAGE buttons. Move the arrow so that it points to the Strings sound. Now you can select variation 1 without affecting the Piano 1 sound.

### Split Mode

You can easily split the keyboard on the PRO 1 and PRO 2 by pressing the SPLIT button. This will divide the keyboard into separate left and right sections with a different sound on each side.

After pressing SPLIT, any sound you select will affect only the sound on the right side of this split. If you want to change the sound on the left side of the split, simply select a sound while holding the SPLIT button down. When the SPLIT button is held in this way, you can also press a key on the keyboard to define a new split point.

# Performances

## What is a performance ?

A Performance is simply a memory location in which a sound or combination of sounds has been stored. Usually, when you use an instrument like the PRO 1 or PRO 2, you will spend some time experimenting with different single sounds or combinations of sounds, different effects etc., until you really get the instrument sounding the way you want. At this stage, the instrument allows you to store all of the settings and changes which you have made into a memory called a PERFORMANCE.

The PRO1 and PRO2 contain 64 performances. Many of these have been programmed at the factory so you can already hear some powerful combinations and sounds before you get into making your own.

## Selecting the Performances

While the procedure for making and storing a performance is covered in the "Quick study guide" section of this manual, you might be interested in listening to some of those which we have created for you. To get to these performances you need to switch from SOUNDS mode to PERF mode using the SOUND/PERF button. This button is located to the right of the sound selection buttons. When the light above the button is ON, the instrument is in SOUNDS mode. When this light is OFF the instrument is in PERF mode.

Once in PERF mode you can begin to use the factory performances. The 64 performances are stored in 8 banks A - H. Each bank contains 8 performances 1-8. If you look beneath the sound buttons you will see that the lower row has the letters A-H and the upper row has the number 1-8.

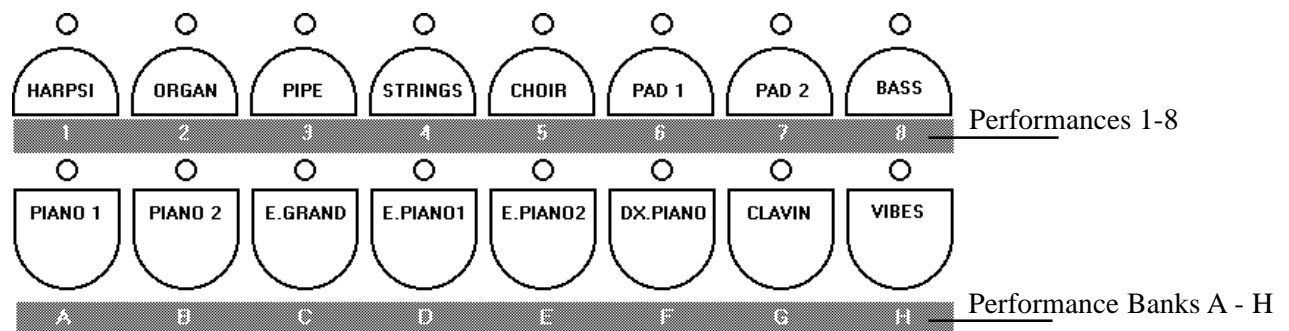

To listen to the performances in bank A, first press A, (PIANO 1 button), and then select the first performance, (button 1 - the HARPSI button.) Now switch to number 2, (the ORGAN button) and so on through number 8, (the BASS button.) When you get to performance A-8, you can switch to the first performance in the B bank - B1 by pressing B, (PIANO 2 button) and then 1, (HARPSI button.)

To return to normal playing, press SOUNDS/PERF so that the light comes on again.

## Changing the pitch of the instrument

---

### Transpose

The TRANSPOSE buttons are located to the left of the sound selection buttons.

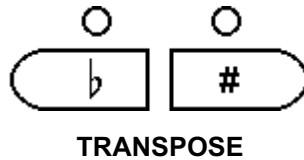

Pressing either button will adjust the pitch of the instrument in half-step (semitone) increments. Each press of the ♭ (flat) button will reduce the pitch of the instrument by one half step. Each press of the ♯ (sharp) button will increase the pitch of the instrument by one half step. In this way it is possible to play a piece in one particular key and transpose the instrument to sound in a different key. Transpose can be cancelled by pressing both buttons together.

When you use the transpose buttons, the amount of transposition is displayed in the screen as a relative value. For example, if you were to press the ♯ button three times a transpose value of “+3” would be displayed. This indicates that each note played would be pitch shifted up by three half steps. If you now play in the key of C, the instrument would sound in the key of Eb, (three half steps above C). If you play in F, the instrument would sound in Ab and so on.

These buttons can also be used for transposing a single sound in a layer or split, (see Section 4 - Volume & Transpose), and transposing a midi instrument, (see Section 5 - Midi Transpose). This feature is most useful for “octave shifting” one of the sounds being used. For one octave up, set the transpose value to +12. For one octave down set the value to -12

### (PRO 2 model only) Tune buttons

The TUNE buttons are located above the TRANSPOSE buttons on the PRO 2 model.

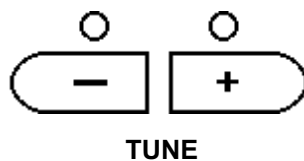

The TUNE feature allows the entire instrument to be tuned to match another instrument or backing track which may be slightly out of tune. Press the + button to increase the pitch and the - button to decrease the pitch.

The tuning display uses a standard reference for the pitch of concert A = 440Hz. The available range is 427.5 - 452.5. You can reset the tuning to A=440Hz by pressing both tuning buttons together

**NOTE:** The TUNE feature is also available on the PRO 1. It can be found under the Master/MIDI button. See page 30 for more details.

## Tone control

---

### (PRO 1 model only) Brilliance controls

The BRILLIANCE controls on the PRO 1 model allow you to adjust the brightness of the instrument's tone.

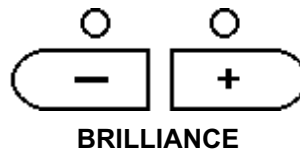

When both LEDs are off, the tone of the instrument is normal. Press the + button for a brighter tone and the - button for a softer tone.

### (PRO 2 model only) EQ Section

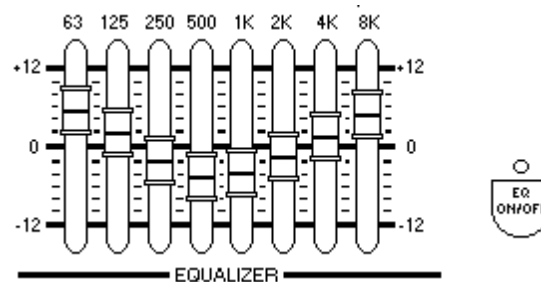

The EQ section of the PRO 2 allows you to accurately adjust the tone color of the sound according to taste. The effects you create with the EQ will be saved into memory when you store a performance. In this way, recalling different performances will automatically adjust the EQ settings according to the way they were when that performance was saved.

The EQ ON/OFF button allows you to disable the effect of the EQ section. Turning this button off will give the equivalent sound of all the EQ sliders being set to mid position, (flat).

*NOTE: Because the EQ settings are recalled along with a performance, the “shape” of the EQ will sometimes be different from the actual positions of the physical sliders. To look at the real “shape” that you’re currently hearing, go to the “Lock EQ” screen in the MASTER/MIDI section. This will show you a graphic representation of the EQ shape which is currently in effect.*

*If the current EQ shape is different from the slider positions as described above, slightly moving each slider will “update” the position of that slider.*

*NOTE 2: Because the EQ section is digital, it is quite normal to hear some noise, (called “zipper noise”), if these sliders are moved while a sound is being played.*

## Adding effects

---

### Reverb

#### Room, Stage, Hall

Both the PRO 1 and PRO 2 offer three reverb presets. These can be selected by repeatedly pressing the REVERB button until the light for the desired effect turns on. The size and depth of these effects can be fully edited using the REVERB SEND and REVERB TIME functions under the PERF EDIT button.

#### (PRO 2 model only) Others

When the “Others” light is displayed in the reverb section, you can use the DATA slider to choose from 13 additional reverb types. These are as follows;

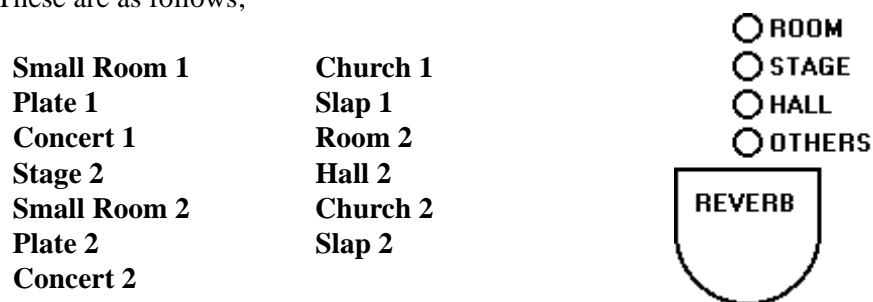

The selected reverb type will remain selected as the “others” preset until a different performance is recalled.

### Effects

#### Chorus, Tremolo, Phaser

Both the PRO 1 and PRO 2 offer three effect presets. These can be selected by repeatedly pressing the EFFECTS button until the light for the desired effect turns on. The depth and rate of these effects can be fully edited using the EFFECT DEPTH and EFFECT RATE functions under the PERF EDIT button.

#### (PRO 2 model only) Others

When the “Others” light is displayed in the effects section, you can use the DATA slider to choose from 13 additional effect types. These are as follows;

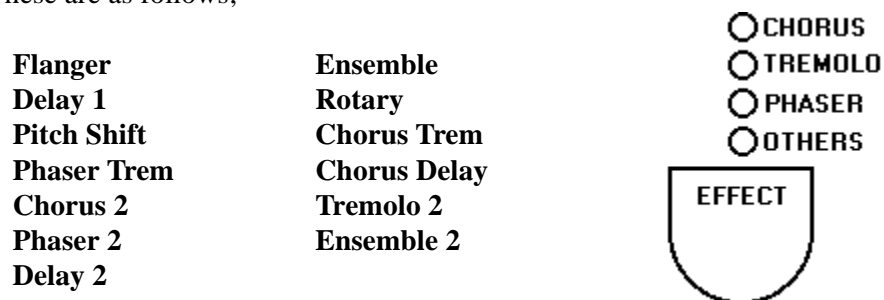

The selected effect type will remain selected as the “others” preset until a different performance is recalled.

*NOTE: Depending on the effect selected, the edit functions offered under PERF EDIT will be different. See the section on PERF EDIT screens 5 & 6 for more details.*

## Keyboard response

---

### Touch

#### **Soft, Normal, Hard**

Both the PRO 1 and PRO 2 offer three different keyboard touch responses or “velocity curves”. These can be selected by repeatedly pressing the TOUCH button until the light for the desired effect turns on. The responses available are;

**SOFT** This is useful for a player with a lighter touch or somebody more accustomed to a synth action keyboard. It requires only a relatively soft touch to achieve maximum volume.

**NORMAL** This setting has been designed to most accurately represent the touch response of a piano

**HARD** This setting is for “stronger” players. It requires a fairly powerful touch to achieve maximum volume.

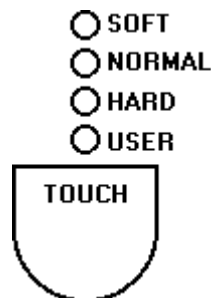

#### **(PRO 2 model only) User**

The USER touch setting allows you to use the DATA slider to accurately adjust the touch response to suit your playing style. With the slider set at minimum, there is almost no touch response, (less than the factory preset SOFT setting). With the slider set at maximum, the response is harder than the factory preset HARD setting. Use the DATA slider to select any value between these two extremes.

## Other controls

---

### Local Off

This button isolates the PRO 2 from its internal sound engine allowing it to be used as a MIDI controller. When Local Off is selected the display will show only the current program number but not the name of the related internal sound.

When in Local Off mode, you may select any bank and program number to be sent to the external MIDI instrument. To do this press the Page up button and use the DATA slider to select a bank number in the range 0-127. Now you can press Page up once more and select any program number in the range 0-127. Configurations created in this way can be stored into performances and the related bank/program number will be sent when the performance is subsequently recalled.

*NOTE: Another way of turning a track to Local Off mode is to press the Page up button when the arrow in the screen is pointing to that particular track. This has the exact same effect as pressing the Local Off button.*

### MIDI Panic

The PRO 1 and PRO 2 feature a hidden “MIDI Panic” function. This function can be used in the event of problems or “lock-ups” during MIDI transmission or reception.

To perform MIDI Panic, first hold the VIBES button and then press the SOUNDS/PERF button.

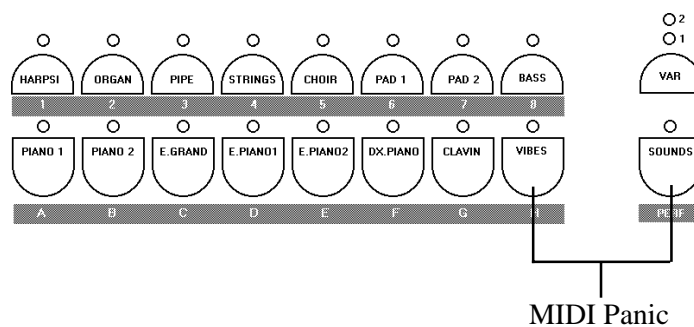

MIDI Panic sends “All Notes Off” and “Reset All Controllers” commands on all active channels.

### Demo

Pressing this button will start playback of the factory pre-programmed demonstration song. This song has a number of different parts which will demonstrate various sounds on the instrument.

---

# *Section 4*

## **Performance Edit**

---

When you construct a combination of sounds there are many powerful features available under the PERF EDIT button which can help you tailor the sound combination to your needs.

## Editing your performance

---

The functions available under PERF EDIT are divided into a series of individual numbered screens. The screen you see when you press the PERF EDIT button will be the last one used during a previous PERF EDIT session. If you have not used PERF EDIT since first switching the instrument on, you will see the first screen - "Volume & Transpose". For each PERF EDIT function, you will see the screen number in the top right corner of the display. You can select the next or previous screen by using the Page Up/Down buttons to the right of the DATA slider.

### Screens for layered and split Sounds

In most cases, each screen contains only one changeable value. You normally use the DATA slider to adjust this value. Although there are only twelve functions available under PERF EDIT, there are many cases in which you will see more than twelve screens. This occurs when two sounds are being used in either split or layer mode. Many screens such as Volume or Reverb Send will appear twice - first for sound 1 and then again for sound 2. When this occurs, the second instance of each screen displays the same screen number but with the addition of a "b". For example, if you layer Piano and Strings, the first screen would be screen 1 - Volume for the Piano sound and the second screen would be Screen 1b - Volume for the Strings. Next you would see screen 2 - Reverb Send for the Piano followed by screen 2b - Reverb send for the Strings. If you were using only one sound then you would not see screens 1b and 2b since these are redundant in a single sound performance.

***NOTE:** When using a layered sound, you can decide which sound you want to be #1 and which sound you want to be #2. This determination is made according to which button you pressed first. If you hold PIANO 1 and then press PAD 1, PIANO 1 will be sound 1 and PAD 1 will be sound 2.*

### Perf Edit functions

Following is a list of the PERF EDIT screens in numeric order. If you see "(b)" by a screen number it indicates that there will be two instances of this screen when a split or layer is being used.

#### 1(b). Volume & Transpose.

In the top line of the screen you will see the name of the sound currently selected. Moving the DATA slider will adjust the volume of this sound.

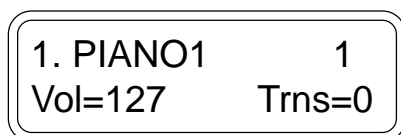

The pitch of the currently displayed sound can be transposed by simply using the TRANSPOSE buttons to the left of the sound selection buttons. This function is most useful for "octave shifting" when using a split or layer. An octave shift can be achieved by setting the transpose value to -12, (one octave lower than normal) or +12, (one octave higher than normal).

#### 2(b). Reverb Send Level

If a reverb effect has been selected, this function can be used to control how much reverb is applied to each sound being used. It works in the same way as an "Effect Send" control on a mixer board. When two sounds are being used, either in split or layer mode, screen 2 controls the reverb amount for Sound 1 and screen 2b controls the reverb amount for Sound 2. If only one sound is being used then screen 2b is not displayed.

### 3. Reverb Time

If a reverb effect has been selected, this function can be used to control the “reverb time” or the delay amount for the particular reverb preset. Basically this allows you to make the overall effect larger or smaller than the factory programmed settings. For example, if you select “HALL” in the reverb section, adjusting the reverb time allows you to create the effect of a larger hall or a smaller hall according to your preference.

### 4(b). Effect Send Level

This function works in exactly the same way as Reverb Send. If an effect has been chosen from the EFFECT group, you can use this function to control how much of the effect is applied to each sound being used. When two sounds are being used, either in split or layer mode, screen 4 controls the reverb amount for Sound 1 and screen 4b controls the reverb amount for Sound 2. If only one sound is being used then screen #4b is not displayed.

### 5. (PRO 1 model only): Effect Depth

This function allows you to control the maximum amount of effect available. If you find, for example, that when you adjust the EFFECT SEND for a particular sound you are still not hearing enough of the effect, you need increase the overall effect depth in this screen.

### 6. (PRO 1 model only): Effect Rate

This function allows you to adjust the speed at which the selected effect “moves” or modulates.

### 5 and 6. (PRO 2 model only) - Effect Editing

The functions available in screen 5 and screen 6 will be different depending on which effect has been selected. These functions allow you to modify the way a particular effect sounds. For example, if TREMOLO is selected, screen 5 will adjust the EFFECT DEPTH, (the total amount of available tremolo) and screen 6 will adjust the EFFECT RATE, (the speed of the tremolo). If, instead, you selected DELAY 1 from the OTHERS group, screen 5 will adjust the DELAY TIME, (the time it takes for a repeat to occur), while screen 6 will adjust the FEEDBACK, (the number of repeats which are heard before the effect fades out).

Here is a list of the different parameters which are available for the 16 effects on the PRO 2.

EFFECT NAME	Pg. 5 Function	Pg. 6 Function
Chorus	Depth	Rate
Tremolo	Depth	Rate
Phaser	Depth	Rate
Flanger	Depth	Rate
Ensemble	Depth	Rate
Delay 1	Delay Time	Feedback
Rotary	Speed	Filter (Khz)
Pitch Shift	Coarse Tune	Fine Tune
Chorus Trem	Depth	Rate
Phaser Trem	Depth	Rate
Chorus Delay	Depth	Delay Time
Chorus 2	Depth	Rate
Tremolo 2	Depth	Rate
Phaser 2	Depth	Rate
Ensemble 2	Depth	Rate
Delay 2	Delay Time	Feedback

## Assigning pedal functions

---

### 7. Pedal 1 Function

### 8. Pedal 2 Function

When a foot pedal is connected to the Pedal 1 or Pedal 2 jack, it can perform a number of different functions. These screens are used to select the function of your choice for each pedal respectively. Each jack can accept either a switch type pedal or a continuous type, (volume), pedal. Whenever a pedal is inserted into one of the available jacks, the instrument performs an “auto-detect” routine and automatically figures out which type of pedal has been inserted. Therefore the functions available in these menus will depend upon which type of pedal has been detected in each jack. The available functions are as follows;

#### ***IF A SWITCH TYPE PEDAL HAS BEEN CONNECTED;***

<b>OFF</b>	The pedal has no function.
<b>DAMPER</b>	The pedal functions like the “right pedal” of a piano - providing a sustain effect to the notes being played.
<b>SOSTENUTO</b>	The pedal functions like the centre pedal of a grand piano - sustaining only those notes which were being held down while the pedal was pressed.
<b>SOFT</b>	The pedal functions like the “left pedal” of a piano - softening the tone of the instrument
<b>START/STOP</b>	(PRO 2 Only.) Duplicates the PLAY/STOP button in the recording section of the PRO 2
<b>PERF +</b>	When the pedal is pressed the next PERFORMANCE is selected.
<b>PERF -</b>	When the pedal is pressed the previous PERFORMANCE is selected.
<b>ROTARY S/F</b>	(PRO 2 Only.) If the ROTARY effect is selected, (simulated “Leslie” type organ effect), the pedal can be used to switch between fast and slow speeds.

#### ***IF A CONTINUOUS (VOLUME) TYPE PEDAL HAS BEEN CONNECTED;***

<b>OFF</b>	The pedal has no function.
<b>VOLUME</b>	The pedal controls the overall volume of the assigned sound with a range of 0 - 127.
<b>EXPRESSION</b>	The pedal controls the overall volume of the assigned sound but the maximum level available will be equal to the volume level set for that sound. For example; if piano and strings are mixed with the strings level set at 75, the expression pedal will sweep from 0 to 75.

### 9. Pedal 1 Assign

### 10. Pedal 2 Assign

### 11. Damper Assign

Using these functions, you can select which of the selected sounds the pedals will affect. In each menu you can assign the pedal to Sound 1, Sound 2 or Sound 1 & 2. For example, if you mixed Piano and Strings and you wanted the damper pedal to sustain the piano but not to affect the strings, you would set the DAMPER ASSIGN screen to “Sound 1”.

---

## 12. Auto Wah-Wah

Auto Wah-Wah is a classic effect from the vintage keyboard era. The effect can be applied to a single sound or to either of the two sounds in a layer or split. Use the DATA slider to assign the effect. The “Auto Wah-Wah” effect is particularly effective on CLAVI and E. PIANO sounds.

## 13. Microtuning

This feature allows you to select from a variety of alternative tunings. The selection available is as follows;

<b>EQUAL</b>	Equal temperament tuning.
<b>PIANO 1</b>	Preferred Stretch tuning method adopted by piano tuners.
<b>PIANO 2</b>	Another popular tuning method favoured by piano tuners.
<b>MEANTONE</b>	Actually, “Meantone C”. A mathematically accurate tuning to optimize the notes of the C scale.
<b>KIRNBERGER</b>	Popular alternate classical tuning.
<b>TARTINI-VALOTTI</b>	Popular alternate classical tuning.
<b>USER</b>	See “User Tuning” below.

### *(PRO 2 model only)* User Tuning

Using this function, you can accurately retune every note of the instrument to recreate a preferred tuning. It is even possible to have a professional piano tuner create any tuning of your choice by using this simple feature.

After using the DATA slider to select MICROTUNING - USER from PERF EDIT page 13, you are ready to create your personal tuning preset. The operation of this function is very simple. Press any key on the keyboard. The screen will “catch” the key that you played. Fig. 1 shows the screen after the key C5 has been played;

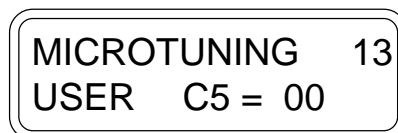

*Fig.1: Creating a USER tuning temperament*

You can now repeatedly play this key and adjust its tuning with the DATA slider. When you have finished tuning this key, simply press another key and proceed as before.

When you have finished tuning all of the keys you need, simply press PERF EDIT, to escape from the edit screen. If you want to reset the user tuning, (this procedure will program the user tuning to be the same as the EQUAL temperament), this can be done from the “Restore Tuning” function under the MASTER/MIDI button. See section 5 of this manual for more details.

## Other features of PERF EDIT

---

### 14. Detune

*NOTE: This function is only available when a layered or split sound is being used.*

Increasing the detune value with the DATA slider will detune sound #1 by the number of cents displayed. Lower values are useful for creating a natural chorus effect between two sounds. At higher values a “Honky Tonk” effect can be achieved.

### 15. Delay Snd 2

*NOTE: This function is only available when a layered sound is being used.*

This feature allows you to apply a delay to the second sound in a layer. In this way, some useful delay effects can be achieved without having to use the effects section, (leaving that section free to apply another effect).

Choose the desired value with the DATA slider. The value shown represents the number of milliseconds which will elapse before the second sound is heard.

## Special features

While in PERF EDIT mode, you can utilize a couple of extra features which give you more flexibility when creating a layered sound.

When two sounds are used together either in split or layer mode it is possible, from the Volume & Transpose screen, the Reverb Send screen or the Effect Send screen to select a different variation of either sound or change the sound without affecting the other sound. When any one of these screens is displayed, the sound selection buttons will appear as though only one sound has been selected. This isolates the individual sound from the layer so you can have more control over it. In this mode you can use the sound selection buttons and the VARI button to change this sound without affecting the other sound.

For example - Mixing Piano 1 (no variation) with Strings variation 1. In SOUNDS mode, press PIANO 1 and STRINGS together, (this will create a mixture of the basic PIANO 1 and basic STRINGS sounds. Next press PERF EDIT and go to screen 1b - Volume, Transpose, Tuning for the STRINGS sound. Notice that, according to the sound selection buttons, only STRINGS appears to be selected. Press the VARI button so that Variation 1 is selected. You can immediately hear the piano sound mixed with this new string sound when you play on the keyboard.

You can also use this method to mix two sounds from the same group. For example; if we wanted to mix Rhodex 1 with Rhodex 2, (that's E. Piano 1, no variation with E. Piano 1, variation 1), we could not achieve this by pressing two buttons together because both sounds reside under the same button. We can create this effect in the following way;

- 1. Mix E. Piano 1 with any other sound.***
- 2. Press PERF EDIT.***
- 3. Use the page buttons to select either the Volume, Reverb or Effect screen for “the other sound”.***
- 4. Now use the sound selection buttons and the VAR button to select E. Piano 1, variation 1.***

Now you can turn off PERF EDIT to return to normal playing or you can continue to edit the sound combination using the other features in PERF EDIT.

---

# *Section 5*

## **Master/MIDI Functions**

---

The Master/MIDI button contains both the MIDI controls of the instrument and a number of important "Master Control Features".

## MIDI functions

---

### (PRO 1 Model Only) Tuning

This feature allows the entire instrument to be tuned to match another instrument or backing track which may be slightly out of tune. The tuning display uses a standard reference for the pitch of concert A = 440Hz. The available range is 427.5 - 452.5.

*NOTE: PRO 2 users have a separate front panel control for this same feature (see page 18).*

### 1. 1.Midi Channel

This allows you to change the “primary MIDI channel” for the instrument. This is both the send and receive channel for the instrument when only one sound is being used across the entire keyboard. In LAYER mode, this becomes the MIDI channel of Sound #1 and in SPLIT mode it becomes the MIDI channel of the right hand or upper sound.

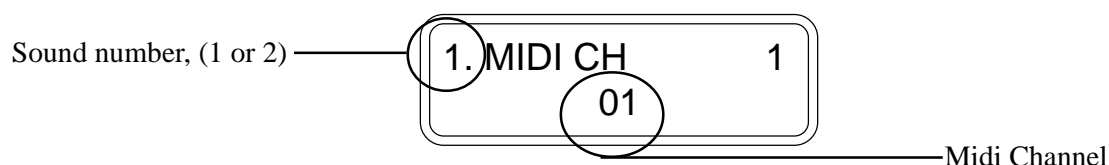

### 2. 2.Midi Channel

This allows you to change the “secondary MIDI channel”. This channel is only in effect when more than one sound is being used - in LAYER or SPLIT modes. The selected channel will be both the send and receive channel for sound #2 - the second sound of a layer or the left hand or lower sound of a split.

### 3. Common Channel

This channel is primarily used for the sending and receiving of PERFORMANCE messages. A program change message received on the common channel will not change one of the individual sounds on the keyboard. Instead, it will be interpreted as a PERFORMANCE CHANGE message.

### 4. Midi Transpose

It is possible, using this function, to have the midi note messages from a particular sound transposed to a higher or lower key. In this way, the PRO 1/PRO 2's internal sounds will not be transposed but the sounds from the attached sound module will play at a different pitch. Use the DATA slider to choose which sounds you want to affect and use the front panel TRANSPOSE buttons to choose the amount of transposition.

This feature is particularly useful when, for example, you might want to mix the internal piano sound with a synth sound from another sound module. When you connect the module via MIDI, you find that the synth voice is playing in the wrong octave. Using the Midi transpose function you can transpose the external synth sound without affecting the internal piano sound.

### 5. Midi IN Filters

This function allows you to block the reception of certain MIDI messages which might be unwanted on some occasions.

For example; if you were playing a midi file from an external sequencer using the ELECTRIC PIANO 2 sound on the PRO 1 or PRO 2, you might find that every time you start playback of the sequence, it switches to PIANO 1. This happens because the sequence includes a Program Change message at the beginning of the song. To overcome this problem, you would select the MIDI IN FILTER for “Program” messages. This means that the instrument would then ignore any Program Change messages that it receives. These messages are said to have been “filtered out” of the incoming MIDI data stream.

---

The messages that can be filtered are as follows;

<b>Program</b>	-	Midi program change messages
<b>Volume</b>	-	Midi volume message
<b>All Cont.</b>	-	All midi controller functions, (volume, modulation, pan etc.)
<b>Prog + Vol</b>	-	Program change and volume
<b>Pedals</b>	-	Hold, sustain, sostenuto, soft
<b>Pitch</b>	-	Pitch bend

## 6. Midi OUT Filters.

This function is used to stop the instrument from transmitting certain MIDI messages which might be unwanted on some occasions.

For example; if you were to connect the instrument to an external MIDI sound module and mix the module's sounds with the instrument's own internal sounds, you might wish to adjust the volume level of the PRO 1/ PRO 2's internal sounds independently without affecting the volume of the sounds in the module. Under normal circumstances, this would not be possible with a regular MIDI connection. When you reduce the volume of the PRO 1/PRO 2 it sends a "Midi Volume" message to the sound module. This message would cause the sound module to reduce in volume also.

Another problem which might occur is, when you select a new sound on the PRO 1/PRO 2, a "Program Change" message would also be sent to the sound module causing its sound to be changed too. Both of these problems could be overcome by selecting the MIDI OUT FILTER for "Prog + Vol". This means that the instrument would no longer send out these unwanted messages. They have been "filtered out" of the MIDI data stream.

The messages that can be filtered are as follows;

<b>Program</b>	-	Midi program change messages
<b>Volume</b>	-	Midi volume message
<b>All Cont.</b>	-	All midi controller functions, (volume, modulation, pan etc.)
<b>Prog + Vol</b>	-	Program change and volume
<b>Pedals</b>	-	Hold, sustain, sostenuto, soft

## 7. Midi Clock.

Use the DATA slider to select the timing clock for the sequencer. There are two options;

<b>Internal</b>	-	The internal metronome controls the sequencer timing
<b>External</b>	-	The MIDI IN signal controls the sequencer timing

## Master functions

---

### 8. Computer

Here you can set the operating mode for the computer serial port on the instrument's back panel. This port allows two-way communication between the instrument and a PC without the need for a MIDI interface. A cable to connect the instrument to your IBM or Macintosh serial port can be obtained from your Generalmusic dealer.

There are three modes which can be selected from this screen. Select the one which is most compatible with your type of computer.

- |                           |   |                                    |
|---------------------------|---|------------------------------------|
| <b>1. Apple Macintosh</b> | - | Any Macintosh computer             |
| <b>2. PC Fast</b>         | - | 80486, Pentium or faster processor |
| <b>3. PC Slow</b>         | - | 80386 or earlier model             |

### 9. Lock MIDI

This feature allows you to "lock" the MIDI settings of the instrument. Normally, the MIDI channels, MIDI transpose settings and MIDI filters are memorized for each performance. This means that, as you recall different performances, the instrument's MIDI settings will change according to the way they were set when that performance was stored.

This function allows you to disable these changes, permitting you to select any performance without changing the current MIDI settings. After you have switched this function on, you may adjust the MIDI settings as you wish. Any subsequent changes that you make to the MIDI settings will remain in effect until you change them again or until you turn off the "Lock MIDI" function.

### 10. Lock Pedals

This feature allows you to "lock" the functions of the three foot pedals. Normally, these pedal functions are memorized for each performance. This means that, as you recall different performances, the pedal functions will change according to the way they were set when that performance was stored.

This function allows you to disable these changes, permitting you to select any performance without changing the pedal settings. After you have switched this function on, you may adjust the pedal settings as you wish. Any subsequent changes that you make to the pedal settings will remain in effect until you change them again or until you turn off the "Lock Pedals" function.

### 11. (PRO 2 Model Only) Lock EQ

Normally, when you store a performance in the PRO 2, the "shape" of the Graphic EQ sliders is memorized and saved into that performance. When you recall that performance, it also recalls the EQ shape, (even though the sliders themselves may be in a different position.)

This function allows you to "lock" the current EQ shape so that you may use the EQ sliders as a "Global control". When "Lock EQ" is turned on, selecting different performances will not affect the EQ settings. This allows you to adjust the EQ effects in real time as needed.

### 12. Display Contrast

Use this function to improve the visibility of the display screen under different lighting conditions. A higher value will give a stronger contrast.

---

### 13. Restore Perfs

This feature allows you to restore all of the factory pre-programmed performances. *NOTE: Doing this will destroy any performances which you have saved into the instrument yourself.*

To activate the function, move the DATA slider until the screen says “All Performances”. Then press the Page up button. Respond to the “Press ^ to restore” prompt by pressing the Page up button once more.

### 14. Restore Tune

This feature allows you to reset the USER tuning temperament, (PERF EDIT page 12). This is a useful feature if you have been trying to create a user tuning unsuccessfully and wish to start from scratch again. This function will not affect special tunings which you have already made and stored into other performances. It simply allows you to reset the current user tuning to EQUAL temperament.

To activate the function, move the DATA slider until the screen says “Press ^ to restore”. Respond to this prompt by pressing the Page up button once more.

### 15. Midi Dump

Using the MIDI dump feature, you can send all of the information currently held in the instrument’s memory to an external storage device such as a MIDI sequencer, data filer, librarian etc. Refer to the instructions of your MIDI software, sequencer or data filer for instructions on how to receive MIDI dumps from other equipment. Here is the procedure for sending and capturing a MIDI dump;

1. *Connect a MIDI cable between the PRO 1/PRO 2 MIDI OUT and the storage device’s MIDI IN.*
2. *Access the MIDI dump feature from the MASTER/MIDI button and use the DATA slider to select “On”.*
3. *Press the Page up button. The screen should show as below;*

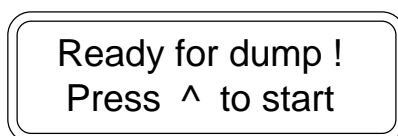

4. *Prepare the storage device to receive a MIDI dump.*
5. *Respond to the “Ready for dump - press ^ to start” by pressing the Page up button once more.*

You will see the dump progress screen until the dump is complete. The time taken for a MIDI dump depends on the amount of data being transferred.

#### To receive a Dump

When you want to send the dumped data back into the PRO 1/PRO 2, it is not necessary to select any special function. Simply connect a cable between the storage device’s MIDI OUT and the instrument’s MIDI IN and begin sending the data. The screen of the PRO 1/PRO 2 will not change while a dump is being received. After the dump is completed you will immediately be able to use your performances, sequences etc. which were transferred during the dump.

---

## 16. Numbering

This feature allows you to select your preferred program numbering system when controlling external instruments in LOCAL OFF mode.

In some sound modules and keyboards the first sound is referred to as program #1 and the last sound as #128. In other systems the first sound is referred to as program #0 and the last sound as #127.

This parameter allows you to select which of the two systems, 0-127 or 1-128, you wish to use. For more information about sending MIDI program changes to external instruments, see the description of the LOCAL OFF feature on page 22.

## 17. (PRO 2 Model Only) Piano Frame

Use this function to adjust the volume of the “Piano Frame” effect between 0 and 127.

The “Piano Frame” effect simulates the natural ambiance or “ringing” of the uppermost strings in a grand piano’s soundboard, (which are always heard to some degree when any note is played.) This effect is only applied to the main Piano 1 sound, (no variation) and will be most noticeable when the instrument is played without reverb.

Although this effect is characteristic of an acoustic piano, some players may prefer to reduce the level of the effect or disable it completely. The recommended level to simulate a 9ft grand piano is 50.

---

# *Section 6*

## **Sequencer / Recorder**

The PRO 2 features a simple but powerful sequencer which allows you to faithfully record your playing or create simple two track songs.

## Play and record

---

The recorder or “sequencer” section in the PRO 2 allows you to record a two-track Song of about 45,000 events, (around 20,000 notes). You can record one track at a time. In playback, you can play along with up to two Sounds in real time, you can deactivate a recorded track and play along with just one recorded track.

### Controls

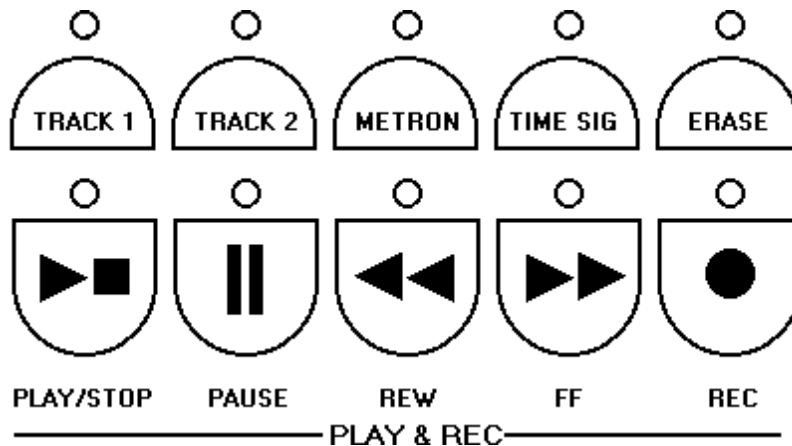

- Play/Stop** Starts and stops either playback or recording.
- Pause** Stops a playback or recording midway. Pressing this button a second time will continue playback from where it was stopped.
- Rewind** “Rewinds” the sequence one bar at a time. You can rewind faster if you hold the button down.
- FF,(Forward)** Advances the sequence one bar at a time. You can scroll forward much faster if you hold the button down.
- Record** Activates Record mode. Recording actually starts when you press the Play or Pause buttons.
- Track 1/2** Buttons that activate the sequencer tracks for recording or playback. The status of each track is indicated by the state of the LED.
- LED off - track is empty or switched off.
  - LED on - track contains data and is ready for playback.
  - LED flashing - track is ready to record or to be overdubbed.
- Metronome** Activates/deactivates the Metronome, (click) and also lets you adjust the record/playback tempo.
- Time Sig.** Offers a selection of Time Signatures and activates the metronome bell. This button is tied to the Metronome function and will only work if the Metronome function is selected.
- Erase** Cancels the events recorded in the sequencer tracks. While pressing this button, press the button for the track you wish to erase. The LED of the erased track goes off to indicate that the track is now empty.

## Quick & easy recording

---

There are two ways to record on the PRO 2:

**A. Record your song just as you play it.**

For example, you may want to record in Layer mode using Concert Grand and Strings.

**B. Record one track at a time.**

While the first recorded track is in playback, you can record the second track. For example, you can record a Bass sound in Track 1 and a Piano sound in Track 2. Refer to the recording procedure detailed on the next page.

### Recording your song just as you play it.

To record something exactly as you play it could not be simpler on the PRO 2;

**1. Press RECORD**



The screen now shows the following;

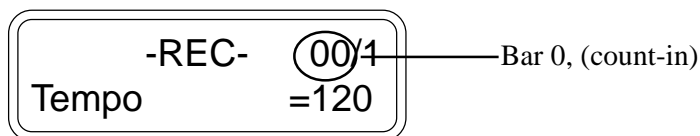

**2. Press PLAY/STOP**



**3. Play something on the keyboard.**

When you have finished playing press PLAY/STOP. You can now listen to what you recorded by pressing PLAY/STOP once again.

### Erasing

To erase what you just recorded in Track 1;

**1. Check that playback is stopped, (bar / beat indicator is not counting)**

**2. Exit record mode by pressing REC to turn it off.**

**3. While holding the ERASE button, press TRACK 1 until the LED goes off.**

## Recording a two track song

---

### Setting up

You can enter record mode after selecting the sound or sounds that you want to use for your recording, or you can select the required sound configuration after entering record mode.

- When you first enter record mode, the PRO 2 will be configured to record a song in 4/4 time with a Tempo of 120 beats per minute.
- The tempo can be adjusted by pressing the METRON. button and using the page buttons to increase or decrease the current tempo.
- You can modify the Time Signature only after activating record mode and before starting the actual recording. Once you start recording, the Time Signature parameter cannot be changed, (Points 3 and 4 below explain more about changing the Tempo and Time signature).

#### 1. *Press the REC button to enter record mode.*

- The LED above the Track 1 button starts to flash.
- In the screen you will see the Song Pointer (1/1) which counts the measures while the sequencer is running. The figure on the left shows the current bar while the second figure on the right shows the current beat.

#### 2. *Select the Sound to record.*

- For example, choose a bass sound so you can play a piano sound on track 2

#### 3. *Activate the Metronome (if required.)*

- The Metronome Volume can be changed with the DATA slider while the Tempo can be changed with the page buttons.

*NOTE: You can only change the Metronome features while the top line of screen displays "METRONOME", (about three seconds after the METRONOME button has been pressed). If you wish to change these features after the screen has reverted to REC mode, simply press the METRON. button once again.*

#### 4. *Choose a Time Signature if you want a bell accent.*

*NOTE: you can only do this if you are using the metronome already. Press TIME SIG and use the page buttons to select the desired timing. The DATA slider will adjust the bell volume.*

*NOTE: Like the Metronome feature, it is only possible to adjust these values within the first three seconds of pressing the TIME SIG button.*

#### 5. *Press the Play button to start the recording.*

- If you chose to use the Metronome, you will hear a one measure count-in before recording actually starts. The display will show this count-in period as measure #0. You should commence playing at 1/1.

#### 6. *Play on the keyboard.*

---

7. **When you have finished, press Play/Stop to stop the recording.**

- The instrument will remain in Record mode.
- The recorded track is confirmed (the relative LED stops flashing and remains permanently on.)

*NOTE: If you pressed REC to exit record mode at this point, you could play along with the recorded track using any sound of your choice.*

8. **Press the Track 2 button.**

- The led above the button starts to flash. You may select a sound for the new track a this stage.

9. **Press the Play button to start recording.**

- Track 1 will playback allowing you to record Track 2 in time with Track 1.

10. **When you have finished recording Track 2, press the Play/Stop button to stop recording.**

- The second track will be confirmed automatically.

11. **Press the Rec button to exit Record mode.**

- The LED indicators of the recorded tracks will remain permanently on.

*NOTE: The sequencer records the initial program changes and any sound changes you make during recording.*

## Playing back the recording

To play back the recording, press Play/Stop.

- During playback, you can deactivate/activate the track of your choice and play along with one or two sounds in real time. Select the Sounds using the normal selection procedure.
- You can deactivate the track of your choice before starting playback.

## Overdubbing

The PRO 2 allows you to record in Overdub mode, letting you add additional events to those already recorded.

- After recording a track, press Pause to stop the recording.
- Press the Rewind button to take the track to the beginning (or to any point before the stop point).
- Press Pause again to start recording from your “cue point”. Anything you now play will be merged with the previously recorded events.

## Erasing

You can cancel the Song entirely or partially by using the Erase function.

### *Partial Erase*

Hold the Erase button and press the track button that you want to erase for about 2-3 seconds. The relative LED above the erased track goes off.

### *Erase all*

Hold the Erase button and press both Track buttons simultaneously. The LED indicators above both buttons will go off.

## Advanced features

---

### Pause / Continue

The PAUSE button actually has two functions;

1. **PAUSE:** To temporarily stop playback while recording or listening.
2. **CONTINUE:** To commence playback or recording from a pre-determined point.

If PAUSE is pressed during playback or recording the song will immediately stop. If you wish to resume playback or recording from the point where you stopped then you must press PAUSE again instead of pressing START/STOP.

The function of the PAUSE button can easily be determined by the state of the LED. If the LED is off then the button will function as PAUSE. If the LED is on then the button will function as CONTINUE.

You can also use the PAUSE button to “cue” a section of a recorded song for overdubbing or to continue recording from where you had previously stopped. While the song playback or recording is paused, use the FF and REW buttons to locate the measure where you want to “pick-up” the recording. Press PAUSE to commence playback from the measure you had selected.

### Using effects with a recording

Your recorded song can utilize effects from the REVERB and EFFECT sections of the instrument.

You must choose the two effects which you want to use before recording the first track.

If you want the first track to use only one of these effects, (or none at all) then, after selecting the TRACK1 button, you should use the REVERB SEND and EFFECT SEND functions under the PERF EDIT button to set the desired levels of both effects for that track.

When you are ready to record the second track, after pressing the TRACK2 button, use REVERB SEND and EFFECT SEND controls once again to set the amount of each effect required for the second track.

### Recording layers and splits

Each track is also capable of recording a layered or split sound. Simply create the layer or split before recording each track.

If you record a layered or split sound into both tracks, the volume of Sound 1 and Sound 2 must be the same for both layers. You can, however, independently control the effect assignment of each sound in each layer or split using REVERB SEND and EFFECT SEND before recording each track. Remember that you must select both effects before recording track 1.

If you recorded track 1 using a split keyboard but you now want to play along using a full keyboard sound, (either to record track 2 or to play live), first commence playback and then turn off the SPLIT button after playback of track 1 has started.

# *Section 7*

**Reference Section**

---



## Technical specifications - PRO 1

---

<b>Keyboard</b>	88 keys, Hammer action
<b>Play Modes</b>	Single, Split (programmable), Layer mode - 2 sounds max 64 programmable performances
<b>Sound Generation</b>	64 oscillators + Dynamic Filter Polyphony: 64 notes maximum, 32 notes minimum
<b>Presets</b>	32 sounds: Piano1, Piano2, El.Grand, El. Piano 1, El.Piano 2, Dx Piano, Clav, Vibes, Harpsi, Organ, Pipe, Strings, Choir, Pad 1, Pad 2, Bass. <i>Each sound has 2 variations.</i>
<b>Effects</b>	Reverb (Room, Stage, Hall), DSP Effects (Chorus, Tremolo, Phaser) Brilliance.
<b>Display</b>	2 x 16 backlit
<b>Sequencer</b>	Demo
<b>Outputs</b>	Midi In/Out/Thru, Stereo Out/Stereo In Pedals, Headphones, Speakers, Computer, Ac in.

## Technical specifications - PRO 2

---

<b>Keyboard</b>	88 keys, Hammer action
<b>Play Modes</b>	Single, Split (programmable), Layer mode - 2 sounds max 64 programmable performances
<b>Sound Generation</b>	128 oscillators + Dynamic Filters Polyphony: 128 notes maximum, 64 notes minimum
<b>Presets</b>	48 sounds: Piano1, Piano2, El.Grand, El. Piano 1, El.Piano 2, Dx Piano, Clav, Vibes, Harpsi, Organ, Pipe, Strings, Choir, Pad 1, Pad 2, Bass. <i>Each sound has 3 variations.</i>
<b>Effects</b>	Reverb (Room, Stage, Hall, Others), DSP Effects (Chorus, Tremolo, Phaser, Others),
<b>Display</b>	2 x 16 backlit
<b>Sequencer</b>	45.000 events. Start/Stop, Pause, FF, Rew, Rec. Track1, Track2, Metronome, Timing, Erase, Demo.
<b>Outputs</b>	Midi In/Out/Thru, Stereo Out/Stero In Pedals, Headphones, Speakers, Computer, Ac in.
<b>Extra</b>	8 band programmable equalizer

## Technology

---

The PRO 1 and PRO 2 feature three unique applications of sound design technology including “physical modelling” to simulate the internal characteristics of a piano soundboard.

### Natural string resonance

The first physical modelling technology, patented by Generalmusic as “*Natural String Resonance*”, allows all of the complex harmonics normally produced by the piano soundboard to be faithfully reproduced. This means that a note’s individual sound will always be slightly different depending upon which other notes are currently being held, (and consequently which strings are un-damped and free to resonate in sympathy). If you hold a low “C” and let the note decay, the strings for that note are still un-damped for as long as the key remains depressed. If you now strike another “C” higher up the keyboard, (staccato), you will hear the sympathetic resonance of the low “C” strings in response to the new note played. This natural effect replicates exactly what happens on a grand piano. If you experiment with different combinations of notes you will hear harmonic colors particular to each. Because this effect is produced by physical modelling and not by samples or DSP effects, the result is a musically and technically accurate simulation of a piano’s soundboard and virtually infinite combinations of harmonics can be produced.

### Damper physical model

The second technology, patented by Generalmusic is “*Damper Physical Model*”. Although it looks like an ordinary damper footswitch, the special continuous damper pedal for the PRO 1 and PRO 2 is not a switch but, instead, a continuous pedal which accurately simulates the effect of the dampers being moved closer to or further away from the strings of the piano. Because of this, effects such as partial or half damping can be achieved. The dampers can even be slowly “squeezed” back against the strings. When the damper pedal is depressed, the damper physical model will simulate the effect of sympathetic resonances being produced by the un-damped strings. Even if you are using a standard switch type pedal, you can hear the effect of the Damper Physical Model by comparing the sounds of notes played in the highest octave of the instrument with and without the damper pedal depressed.

### Advanced release technology

The third and final technology applied to the piano sounds in the PRO 1 and PRO 2 is “*Advanced Release Technology*”, (patent pending). Sample based electronic pianos traditionally use envelope generators to control what happens when a key is released. This simply allows the sample loop to continue for a set period of time until it’s amplitude is reduced to zero by the envelope generator. In an acoustic piano, vibrating strings are silenced by the action of a damper making contact with the string. When this happens, depending on the velocity with which the key was struck and the length of the string itself, certain frequencies are damped earlier than others producing a distinctive harmonic “ring” as the different frequencies in the string’s tone dissipate throughout the piano soundboard. The Key Release Model in the PRO 1 and PRO 2 simulates exactly this feature with complete accuracy throughout the 88 note range.



# Index

---

## A

Advanced release technology .....	45
All Notes Off .....	22
Alternate tunings .....	27
Auto detect, (pedal) .....	8
Auto Wah-Wah .....	27

## B

Bank number, (MIDI) .....	22
Basic functions .....	10
Bell accent .....	38
Brilliance .....	19
Bulk Dump .....	33

## C

Common Channel .....	30
Computer port .....	6, 32
Continue function, (sequencer) .....	40
Continuous damper pedal .....	8
Contrast .....	32
Cue, (sequencer) .....	40

## D

D.C. power jack .....	6, 12
Damper pedal assign .....	26
Damper pedal .....	8
Damper physical model .....	45
DATA slider .....	11
Delay Sound 2 .....	28
Detune .....	28
Display Contrast .....	32
Dynamic sensitivity, (touch) .....	21

## E

Effects .....	20, 25
Effects Selection tables (PRO 2) .....	Appendix, vii
Effects, (using when recording) .....	40
EQ Section .....	19
EQ Lock .....	32
Equal tuning .....	27
Erase .....	36
External Clock .....	31

## F

Factory performances .....	12
FF, (Fast forward) .....	36
Frame effect .....	34
Front panel controls .....	4, 5

## G

Generalmusic damper pedal .....	8
---------------------------------	---

## H

Hard touch setting .....	21
Headphones .....	7

## I

IBM serial port .....	32
Input jacks .....	6

## K

Keyboard response .....	21
Kirnberger tuning .....	27

## L

Layering sounds .....	16
Layout .....	4, 5
L.C.D contrast .....	32
Left /Mono input .....	6
Left/Mono output .....	6
Local Off .....	22
Lock EQ .....	32
Lock MIDI .....	32
Lock Pedals .....	32

## M

Macintosh serial port .....	32
Master/MIDI button .....	29
Meantone tuning .....	27
Metronome .....	36
Microtuning .....	27
Midi Channels .....	30
Midi Clock .....	31
Midi Dump .....	33
Midi Filters .....	30, 31
MIDI Implementation Chart .....	Appendix, iii, v
MIDI jacks, (in, out, thru) .....	6
MIDI Panic .....	22
Midi Transpose .....	30
Mixing sounds .....	16

## N

Naming a performance .....	12
Natural string resonance .....	45
Normal touch .....	21
Numbering .....	34

<b>O</b>		<b>S</b>	
Octave shift, (transpose) .....	18, 24	Saving performances .....	12
“Others”, (reverb and effects) .....	20	Sequencer controls .....	36
Output jacks .....	6	Serial port .....	32
Overdubbing .....	39	Simple recording .....	37
<b>P</b>		Soft touch .....	21
Page buttons .....	11	Sostenuto / soft pedal .....	8, 26
Panic function .....	22	SOUNDS/PERF button .....	10
Pause / Continue .....	36, 40	Speaker jack .....	6
Pedal 1/2 Assign .....	26	Special Control Changes .....	Appendix, iv, vi
Pedal connections .....	8	Specifications .....	43, 44
PERF EDIT .....	11, 24	Split button .....	10
PERF mode .....	10	Split Mode .....	16
PERFORMANCE memories .....	12	<b>T</b>	
Physical modelling technology .....	45	Tartini-Valotti tuning .....	27
Piano Frame effect .....	34	Technical specifications .....	43, 44
Play and record .....	36	Technology .....	45
Polyphony .....	43, 44	Tempo .....	38
Power switch .....	7	Time signature .....	38
Program number .....	22	Touch .....	21
<b>Q</b>		Transpose .....	18, 24
Quick Piano function .....	14	Tuning, (PRO 2) .....	18
<b>R</b>		Tuning, (PRO 1) .....	30
Rear panel connections .....	6	Two track recording .....	38
Record button .....	36	<b>U</b>	
Recording .....	37	User touch .....	21
Reset All Controllers .....	22	User tuning .....	27
Restore Performances .....	33	<b>V</b>	
Restore user tuning .....	33	Variations .....	16
Reverb .....	20	Velocity curves .....	21
Reverb Send .....	24	Volume, (split / layer mode) .....	13, 24
Reverb Time .....	25	Volume pedal .....	8, 26
Rewind .....	36	<b>W</b>	
Right input .....	6	Wah-Wah .....	27
Right output .....	6		

---

## **FEDERAL COMMUNICATIONS COMMISSION**

*Note: This equipment has been tested and found to comply with the limits for a Class B digital device, pursuant to Part 15 of FCC Rules. These limits are designed to provide reasonable protection against harmful interference in a residential installation. This equipment generates, uses, and can radiate radio frequency energy and, if not installed and used in accordance with the instructions, may cause harmful interference to radio communications. However, there is no guarantee that interference will not occur in a particular installation. If this instrument does cause harmful interference to radio or television reception, which can be determined by turning the instrument off and on, the user is encouraged to try to correct the interference by one or more of the following measures:*

- *Reorient or relocate the receiving antenna.*
- *Increase the separation between the equipment and the receiver.*
- *Connect the equipment into an outlet on a circuit different from that to which the receiver is connected.*
- *Consult the dealer or an experienced radio/TV technician for help.*

***CAUTION:** Changes or modifications to this product not expressly approved by the manufacturer could void the user's authority to operate this product.*



---

*Appendix*  
*Appendice*  
*Appendix*  
*Anhang*  
*Bijlage*  
*Apéndice*  
*Appendix*

---

The Appendix contains all information regarding MIDI implementation for PRO1 and PRO2.

L'Appendice contiene informazioni sulle implementazioni MIDI per il PRO1 e PRO2.

L'Appendix contient des informations relatives aux implémentations MIDI de PRO1 et PRO2.

Im Anhang sind Informationen bezüglich der MIDI-Implementationen zum PRO 1 und PRO 2 enthalten.

De Bijlage bevat alle MIDI implementatie informatie voor de PRO 1 en 2.

El Apéndice contiene información relativa a las implementaciones MIDI para PRO 1 y PRO 2.

Appendix indeholder alle informationer angående MIDI implementation for PRO1 og PRO2.





# GENERALMUSIC Special Control Changes

## RP PRO 1 KEYS selection

Bn 75 00	Push key DEMO	Bn 76 00	Release key DEMO
Bn 75 01	Push key MASTER/MIDI	Bn 76 01	Release key MASTER/MIDI
Bn 75 02	Push key TRANSPOSE b	Bn 76 02	Release key TRANSPOSE b
Bn 75 03	Push key TUNE -	Bn 76 03	Release key TUNE -
Bn 75 04	Push key TRANSPOSE #	Bn 76 04	Release key TRANSPOSE #
Bn 75 05	Push key TUNE +	Bn 76 05	Release key TUNE +
Bn 75 06	Push key PIANO 1	Bn 76 06	Release key PIANO 1
Bn 75 07	Push key HARPSI	Bn 76 07	Release key HARPSI
Bn 75 08	Push key PIANO 2	Bn 76 08	Release key PIANO 2
Bn 75 09	Push key ORGAN	Bn 76 09	Release key ORGAN
Bn 75 0A	Push key E. GRAND	Bn 76 0A	Release key E. GRAND
Bn 75 0B	Push key PIPE	Bn 76 0B	Release key PIPE
Bn 75 0C	Push key E. PIANO 1	Bn 76 0C	Release key E. PIANO 1
Bn 75 0D	Push key STRINGS	Bn 76 0D	Release key STRINGS
Bn 75 0E	Push key E. PIANO 2	Bn 76 0E	Release key E. PIANO 2
Bn 75 0F	Push key CHOIR	Bn 76 0F	Release key CHOIR
Bn 75 10	Push key DXPIANO	Bn 76 10	Release key DXPIANO
Bn 75 11	Push key PAD1	Bn 76 11	Release key PAD1
Bn 75 12	Push key CLAVIN	Bn 76 12	Release key CLAVIN
Bn 75 13	Push key PAD2	Bn 76 13	Release key PAD2
Bn 75 14	Push key VIBES	Bn 76 14	Release key VIBES
Bn 75 15	Push key BASS	Bn 76 15	Release key BASS
Bn 75 16	Push key SOUNDS	Bn 76 16	Release key SOUNDS
Bn 75 17	Push key SPLIT	Bn 76 17	Release key SPLIT
Bn 75 18	Push key REVERB	Bn 76 18	Release key REVERB
Bn 75 19	Push key EFFECT	Bn 76 19	Release key EFFECT
Bn 75 1A	Push key TOUCH	Bn 76 1A	Release key TOUCH
Bn 75 1B	Push key VAR	Bn 76 1B	Release key VAR
Bn 75 1C	Push key LOCAL OFF	Bn 76 1C	Release key LOCAL OFF
Bn 75 1D	Push key —	Bn 76 1D	Release key —
Bn 75 1E	Push key D	Bn 76 1E	Release key D
Bn 75 1F	Push key STORE	Bn 76 1F	Release key STORE
Bn 75 20	Push key PERF EDIT	Bn 76 20	Release key PERF EDIT

## RP PRO 1 EFFECTS selection

Bn 0C 00	Reverb OFF	Bn 0D 00	DSP Effects OFF
Bn 0C 01	Reverb ROOM	Bn 0D 01	DSP Effects CHORUS
Bn 0C 02	Reverb STAGE	Bn 0D 02	DSP Effects TREMOLO
Bn 0C 03	Reverb HALL	Bn 0D 03	DSP Effects PHASER



# GENERALMUSIC Special Control Changes

## RP PRO 2 KEYS selection

Bn 75 00	Push key STORE	Bn 76 00	Release key STORE
Bn 75 01	Push key MASTER/MIDI	Bn 76 01	Release key MASTER/MIDI
Bn 75 02	Push key TRANSPOSE b	Bn 76 02	Release key TRANSPOSE b
Bn 75 03	Push key TUNE -	Bn 76 03	Release key TUNE -
Bn 75 04	Push key TRANSPOSE #	Bn 76 04	Release key TRANSPOSE #
Bn 75 05	Push key TUNE +	Bn 76 05	Release key TUNE +
Bn 75 06	Push key PIANO 1	Bn 76 06	Release key PIANO 1
Bn 75 07	Push key HARPSI	Bn 76 07	Release key HARPSI
Bn 75 08	Push key PIANO 2	Bn 76 08	Release key PIANO 2
Bn 75 09	Push key ORGAN	Bn 76 09	Release key ORGAN
Bn 75 0A	Push key E. GRAND	Bn 76 0A	Release key E. GRAND
Bn 75 0B	Push key PIPE	Bn 76 0B	Release key PIPE
Bn 75 0C	Push key E. PIANO 1	Bn 76 0C	Release key E. PIANO 1
Bn 75 0D	Push key STRINGS	Bn 76 0D	Release key STRINGS
Bn 75 0E	Push key E. PIANO 2	Bn 76 0E	Release key E. PIANO 2
Bn 75 0F	Push key CHOIR	Bn 76 0F	Release key CHOIR
Bn 75 10	Push key DXPIANO	Bn 76 10	Release key DXPIANO
Bn 75 11	Push key PAD1	Bn 76 11	Release key PAD1
Bn 75 12	Push key CLAVIN	Bn 76 12	Release key CLAVIN
Bn 75 13	Push key PAD2	Bn 76 13	Release key PAD2
Bn 75 14	Push key VIBES	Bn 76 14	Release key VIBES
Bn 75 15	Push key BASS	Bn 76 15	Release key BASS
Bn 75 16	Push key SOUNDS	Bn 76 16	Release key SOUNDS
Bn 75 17	Push key VAR	Bn 76 17	Release key VAR
Bn 75 18	Push key REVERB	Bn 76 18	Release key REVERB
Bn 75 19	Push key EFFECT	Bn 76 19	Release key EFFECT
Bn 75 1A	Push key TOUCH	Bn 76 1A	Release key TOUCH
Bn 75 1B	Push key PLAY	Bn 76 1B	Release key PLAY
Bn 75 1C	Push key REC	Bn 76 1C	Release key REC
Bn 75 1D	Push key —	Bn 76 1D	Release key —
Bn 75 1E	Push key D	Bn 76 1E	Release key D
Bn 75 1F	Not used	Bn 76 1F	Not used
Bn 75 20	Push key TRACK 1	Bn 76 20	Release key TRACK 1
Bn 75 21	Push key PAUSE	Bn 76 21	Release key PAUSE
Bn 75 22	Push key TRACK 2	Bn 76 22	Release key TRACK 2
Bn 75 23	Push key REW	Bn 76 23	Release key REW
Bn 75 24	Push key METRON	Bn 76 24	Release key METRON
Bn 75 25	Push key FF	Bn 76 25	Release key FF
Bn 75 26	Push key TIMING	Bn 76 26	Release key TIMING
Bn 75 27	Not used	Bn 76 27	Not used
Bn 75 28	Push key ERASE	Bn 76 28	Release key ERASE
Bn 75 29	Push key LOCAL OFF	Bn 76 29	Release key LOCAL OFF
Bn 75 2A	Push key DEMO	Bn 76 2A	Release key DEMO
Bn 75 2B	Push key EQ. ON/OFF	Bn 76 2B	Release key EQ. ON/OFF
Bn 75 2C	Push key SPLIT	Bn 76 2C	Release key SPLIT
Bn 75 2D	Push key PERF EDIT	Bn 76 2D	Release key PERF EDIT

## RP PRO 2 EFFECTS selection

Bn 0C 00	Reverb OFF	Bn 0D 00	DSP Effects OFF
Bn 0C 01	Reverb ROOM 1	Bn 0D 01	DSP Effects CHORUS 1
Bn 0C 02	Reverb STAGE 1	Bn 0D 02	DSP Effects TREMOLO 1
Bn 0C 03	Reverb HALL 1	Bn 0D 03	DSP Effects PHASER 1
Bn 0C 04	Reverb SMALL ROOM 1	Bn 0D 04	DSP Effects FLANGER
Bn 0C 05	Reverb CHURCH 1	Bn 0D 05	DSP Effects ENSEMBLE 1
Bn 0C 06	Reverb PLATE 1	Bn 0D 06	DSP Effects DELAY 1
Bn 0C 07	Reverb SLAP 1	Bn 0D 07	DSP Effects ROTARY
Bn 0C 08	Reverb CONCERT 1	Bn 0D 08	DSP Effects 3PITCH SHIFT
Bn 0C 09	Reverb ROOM 2	Bn 0D 09	DSP Effects CHORUS TREMOLO
Bn 0C 0A	Reverb STAGE 2	Bn 0D 0A	DSP Effects PHASER TREMOLO
Bn 0C 0B	Reverb HALL 2	Bn 0D 0B	DSP Effects CHORUS DELAY
Bn 0C 0C	Reverb SMALL ROOM 2	Bn 0D 0C	DSP Effects CHORUS 2
Bn 0C 0D	Reverb CHURCH 2	Bn 0D 0D	DSP Effects TREMOLO 2
Bn 0C 0E	Reverb PLATE 2	Bn 0D 0E	DSP Effects PHASER 2
Bn 0C 0F	Reverb SLAP 2	Bn 0D 0F	DSP Effects ENSEMBLE 2
Bn 0C 10	Reverb CONCERT 2	Bn 0D 10	DSP Effects DELAY 2

---

## Sound table

<b>PC</b>	<b>Sound</b>		
00	Piano1	16	RockPian
01	Piano2	17	HonkyTnk
02	ElGrand1	18	ElGrand2
03	Rhodex1	19	Rhodex2
04	Wurlitz1	20	Wurlitz2
05	DxPiano1	21	DxPiano2
06	Clavin.1	22	SynClavi
07	Vibes	23	Marimb
08	Harpsi1	24	Harpsi2
09	Organ1	25	Organ2
10	Pipe1	26	Pipe2
11	Strings	27	AtkStrin
12	Choir	28	AtkChoir
13	MuteSynt	29	SlowSynt
14	StrBell	30	SlowBell
15	A.Bass	31	E.Bass

## Performance table

Performance	Bank/N.	PC	Sound comb.	Mode	Performance	Bank/N.	PC	Sound comb.	Mode
GrandP	A1	00	Piano1	Single	Wurlytz1	E1	32	Wurlitz1	Single
Shepherd Moods	A2	01	Piano1, Choir	Layer	Wurlytz2	E2	33	Wurlitz1	Single
Scrap Metal	A3	02	ElGrand1, Rhodex2	Layer	Wurly/Stack1	E3	34	Wurlitz1, DxPiano2	Layer
Tone Grit	A4	03	Clavin1, Clavin1	Layer	Wurly/Stack2	E4	35	Wurlitz1, Rhodex1	Layer
80's Ballad	A5	04	DxPiano, ElGrand1	Layer	Wurly/Stack3	E5	36	Wurlitz1, Rhodex2	Layer
Pop Piano	A6	05	ElGrand1, StrBell	Layer	Wurly/Stack4	E6	37	Wurlitz2, ElGrand1	Layer
Early 70's	A7	06	Rhodex2, Wurlitz1	Layer	Wurly/Stack5	E7	38	Wurlitz2, DxPiano2	Layer
Lounge Lizard	A8	07	Piano2, A.Bass	Split	Wurly/Stack6	E8	39	Wurlitz1, E.Bass	Layer
Piano/Pad1	B1	08	Piano1, MuteSynt	Layer	Dx/ThinPiano1	F1	40	DxPiano1	Single
Piano/Pad2	B2	09	Piano1, StrBell	Layer	Dx/ThinPiano2	F2	41	DxPiano1, DxPiano1	Layer
Piano/Pad3	B3	10	Piano1, SlowSynt	Layer	Dx/ThinPiano3	F3	42	DxPiano1, DxPiano2	Layer
Piano/Pad4	B4	11	Piano1, SlowBell	Layer	Dx/ThinPiano4	F4	43	DxPiano2, Rhodex2	Layer
Piano/Strings1	B5	12	Piano1, Strings	Layer	Dx/Layer1	F5	44	DxPiano1, MuteSynt	Layer
Piano/Strings2	B6	13	Piano1, AtkStri	Layer	Dx/Layer2	F6	45	DxPiano1, Strings	Layer
Piano/Choir1	B7	14	Piano1, Choir	Layer	Dx/Layer3	F7	46	DxPiano1, Choir	Layer
Piano/Choir2	B8	15	Piano1, AtkChoir	Layer	MixedThin	F8	47	DxPiano2, Vibes	Layer
Electric Grand	C1	16	ElGrand2	Single	Clavinet	G1	48	Clavin1	Single
Electric/Stack2	C2	17	ElGrand1, Clavin1	Layer	Clavinet/Phase	G2	49	Clavin1	Single
Electric/Stack3	C3	18	ElGrand2, Rhodex1	Layer	Clavinet/Stack1	G3	50	Clavin1, Harpsi1	Layer
Electric/Stack4	C4	19	ElGrand2, DxPiano1	Layer	Clavinet/Stack3	G4	51	Clavin1, SynClavi	Layer
Electric/Stack5	C5	20	ElGrand1, DxPiano2	Layer	Strings	G5	52	Strings, MuteSynt	Layer
Electric/Stack6	C6	21	ElGrand2, Wurlitz1	Layer	Barock	G6	53	Harpsi2, Strings	Layer
Electric/Stack7	C7	22	ElGrand1, SlowBell	Layer	Chiffer Pad	G7	54	StrBell, Choir	Layer
Electric/Stack8	C8	23	ElGrand1, Vibes	Layer	Warm Pad	G8	55	SlowSynt, Strings	Layer
Rhodex1	D1	24	Rhodex1	Single	BigPad1	H1	56	Choir, StrBell	Layer
Rhodex2	D2	25	Rhodex1	Single	BigPad2	H2	57	SlowBell, Strings	Layer
Rhodex3	D3	26	Rhodex2	Single	BigPad3	H3	58	Pipe1, SlowBell	Layer
Rhodex4	D4	27	Rhodex1	Single	Hammond1	H4	59	Organ1	Single
Rhodex5	D5	28	DxPiano1, Rhodex1	Layer	Hammond2	H5	60	Organ1, Organ2	Layer
Thin/Choir	D6	29	Rhodex2, Choir	Layer	Hammond3	H6	61	Organ1, Pipe	Layer
Rhodex/Pad	D7	30	Rhodex1, MuteSynt	Layer	Church1	H7	62	Pipe1, ExtBk	Layer
Super Rhodex	D8	31	Rhodex1, Rhodex2	Layer	Church21	H8	63	Pipe1, Pipe2	Layer

## FEDERAL COMMUNICATIONS COMMISSION

*Note: This equipment has been tested and found to comply with the limits for a Class B digital device, pursuant to Part 15 of FCC Rules. These limits are designed to provide reasonable protection against harmful interference in a residential installation. This equipment generates, uses, and can radiate radio frequency energy and, if not installed and used in accordance with the instructions, may cause harmful interference to radio communications. However, there is no guarantee that interference will not occur in a particular installation. If this instrument does cause harmful interference to radio or television reception, which can be determined by turning the instrument off and on, the user is encouraged to try to correct the interference by one or more of the following measures:*

- *Reorient or relocate the receiving antenna.*
- *Increase the separation between the equipment and the receiver.*
- *Connect the equipment into an outlet on a circuit different from that to which the receiver is connected.*
- *Consult the dealer or an experienced radio/TV technician for help.*

**CAUTION:** *Changes or modifications to this product not expressly approved by the manufacturer could void the user's authority to operate this product.*

**Stock Code 271099**

Specifications are subject to change without prior notice.  
Specifiche soggette a cambiamento senza preavviso.  
Les spécifications sont sujettes à modifications sans préavis.  
Änderungen -auch ohne Vorankündigung- sind vorbehalten  
Wijzigingen onder voorbehoud  
Especificaciones sujetas a cambios sin aviso previo.  
Specifikationer kan ændres uden forudgående varsel

**PRINTED IN ITALY**

